

Clearance Publish

Clearance=50mm



Clearance Computation Specification

Products Selected

Clearance Computation Specification			
Products Selected			
ATCNHX_0002 BARREL PIN ASSEMBLY - FOR ROUND SCAFFOLDING	ATCNLE_0002 LE END-CAP CALORIMETER - SIDE A	43.69	Not inspected
	ATCNSB_0011 BARREL CALORIMETER SERVICES - IN SECTOR 1 ON SIDE C(A)	1.06	Not inspected
	ATCNSB_0012 BARREL CALORIMETER SERVICES - IN SECTOR 3(7) ON SIDE C(A)	1.06	Not inspected
	ATCNSB_0013 BARREL CALORIMETER SERVICES - IN SECTOR 5 ON SIDE A	1.06	Not inspected
	ATCNSB_0014 BARREL CALORIMETER SERVICES - IN SECTOR 5 ON SIDE C	1.06	Not inspected

Computation Result:

ATCNHX_0002 BARREL PIN
ASSEMBLY - FOR ROUND
SCAFFOLDING

ATCNLE_0002 LE END-CAP
CALORIMETER - SIDE A

Vector coordinate
 $\Delta X \approx 40.82\text{mm}$ $\Delta Y \approx 15.57\text{mm}$ $\Delta Z \approx -0.19\text{mm}$

43.69mm

Not inspected

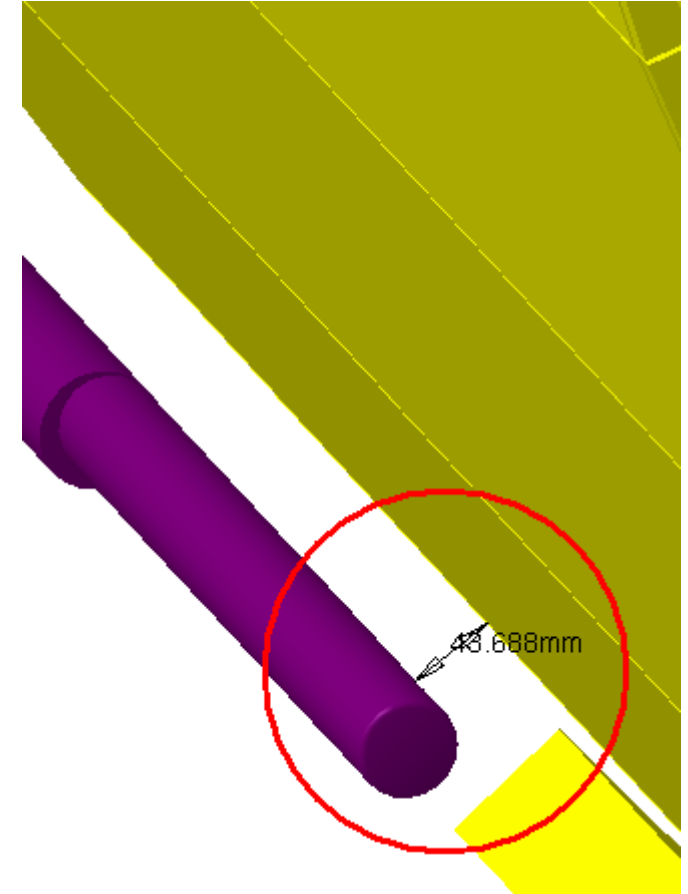
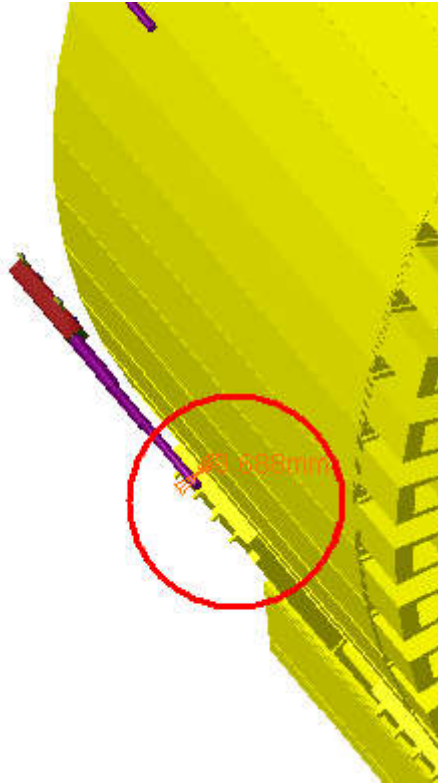
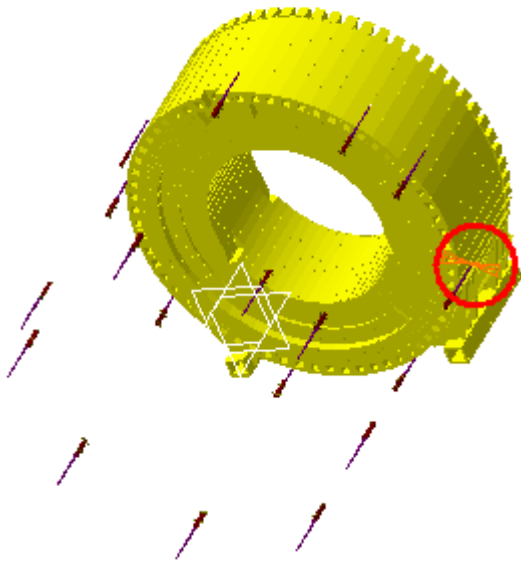

Side A
Sector 10

ATCNHX_0002 BARREL PIN ASSEMBLY - FOR ROUND SCAFFOLDING	ATCNSB_0011 BARREL CALORIMETER SERVICES - IN SECTOR 1 ON SIDE C(A)	Vector coordinate $\Delta X \approx 0.36\text{mm}$ $\Delta Y \approx 1\text{mm}$ $\Delta Z \approx -0.01\text{mm}$	1.06mm	Not inspected
---	--	---	--------	---------------

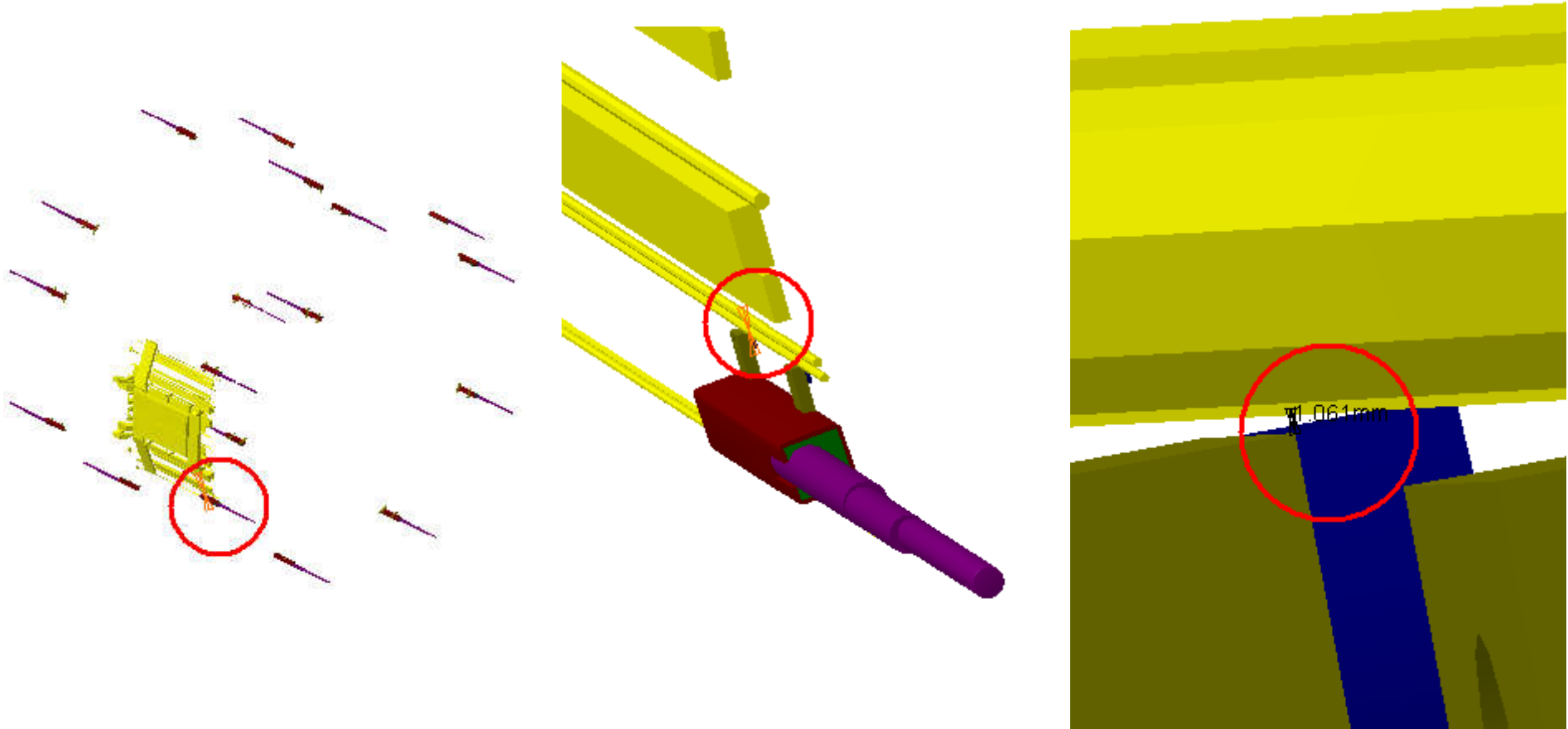

Side C

Sector 16

ATCNHX_0002 BARREL PIN ASSEMBLY - FOR ROUND SCAFFOLDING	ATCNSB_0012 BARREL CALORIMETER SERVICES - IN SECTOR 3(7) ON SIDE C(A)	Vector coordinate $\Delta X \approx -0.79\text{mm}$ $\Delta Y \approx 0.71\text{mm}$ $\Delta Z \approx -0.01\text{mm}$	1.06mm	Not inspected
---	---	---	--------	---------------

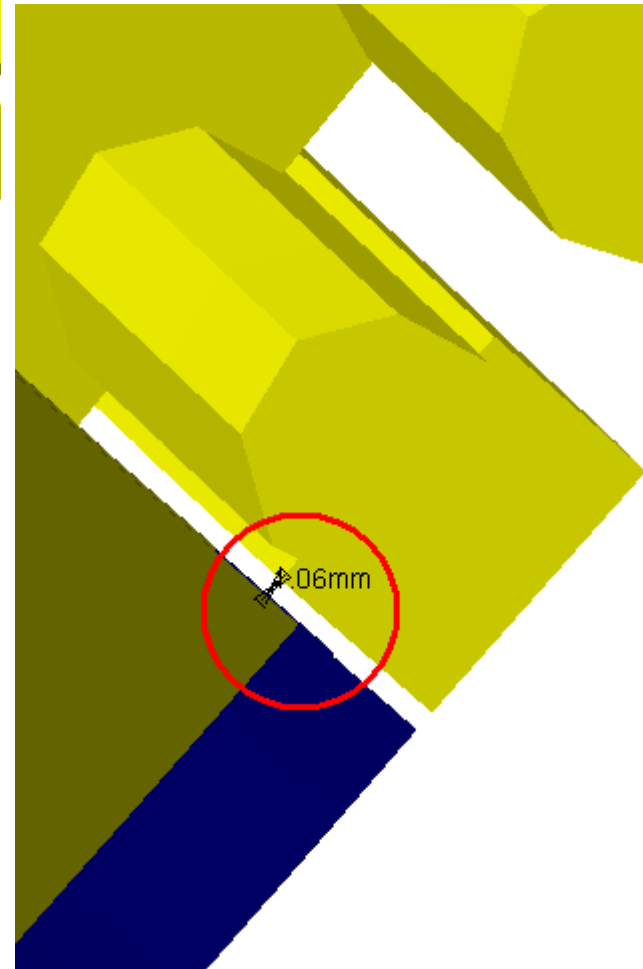
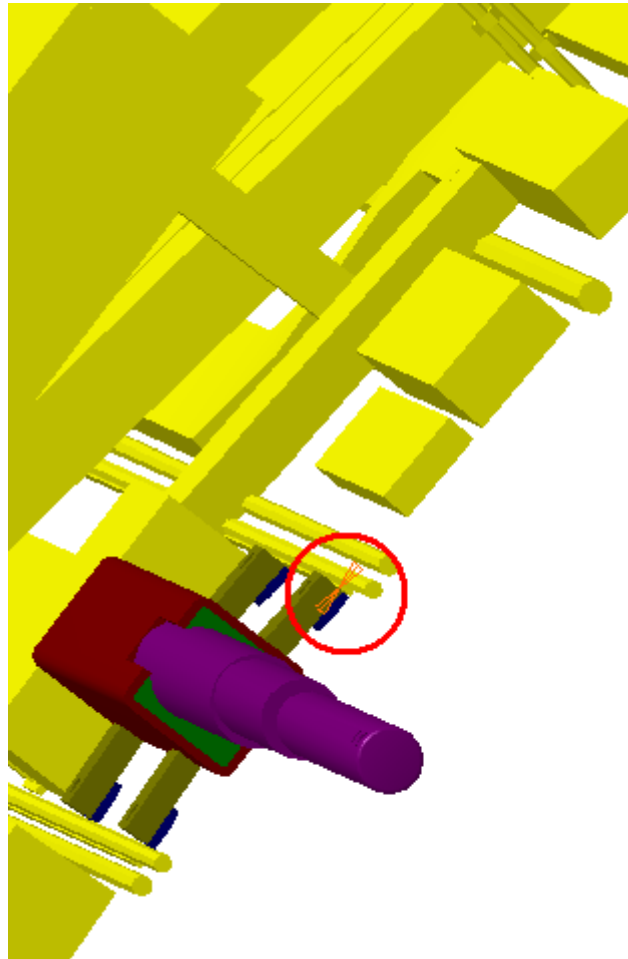
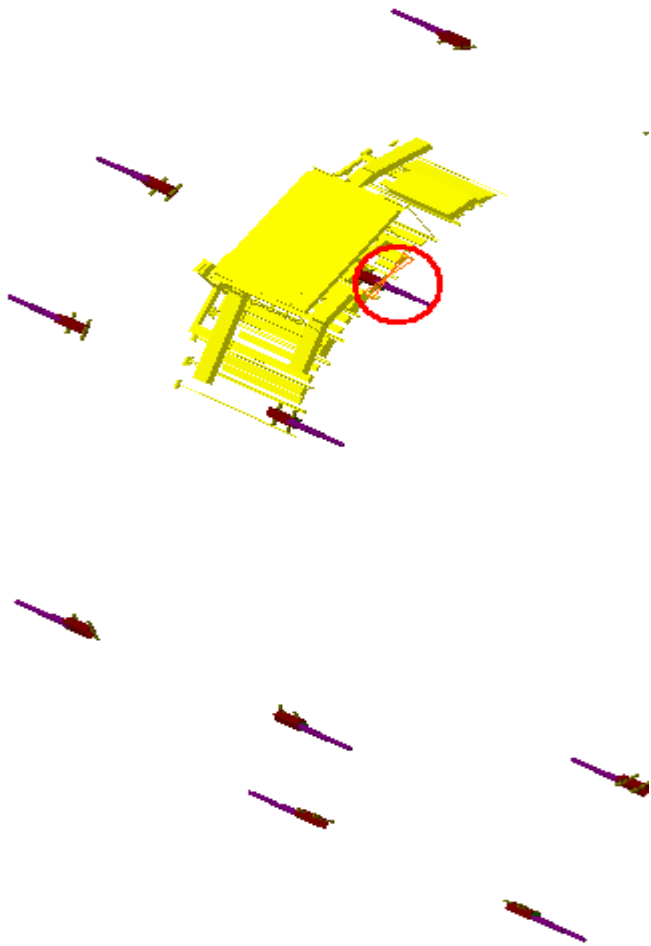

Side C
Sector 3

ATCNHX_0002 BARREL PIN ASSEMBLY - FOR ROUND SCAFFOLDING	ATCNSB_0013 BARREL CALORIMETER SERVICES - IN SECTOR 5 ON SIDE A	Vector coordinate $\Delta X \approx -1.06\text{mm}$ $\Delta Y \approx -0.05\text{mm}$ $\Delta Z \approx 0\text{mm}$	1.07mm	Not inspected
---	---	--	--------	---------------

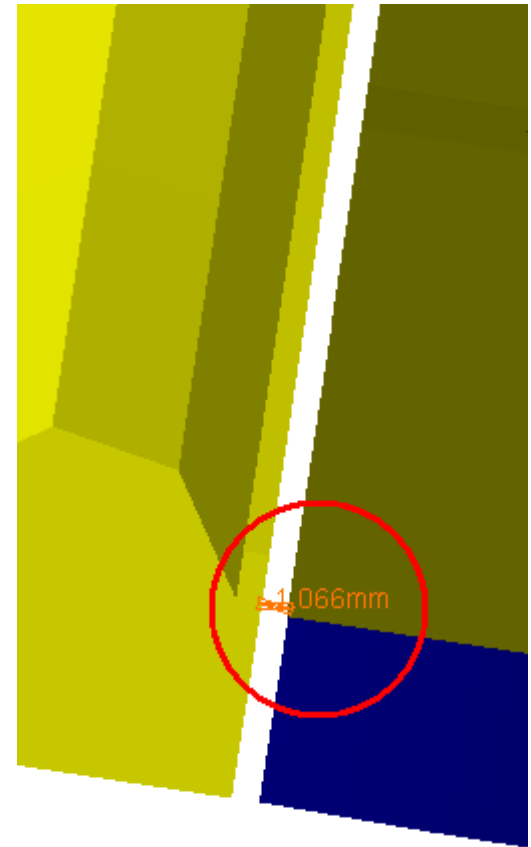
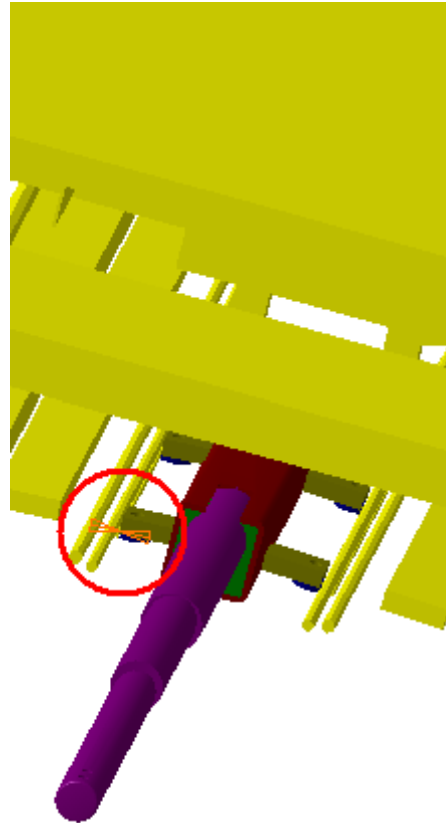
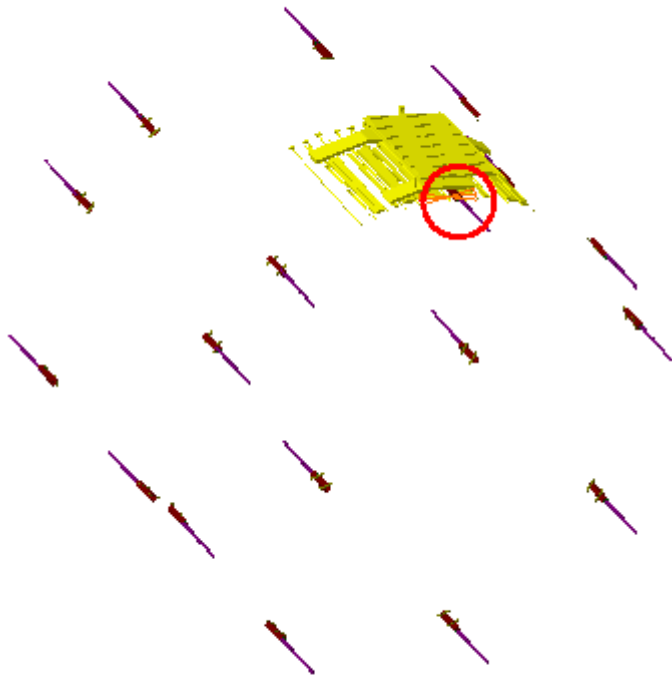

Side A
Sector 5

ATCNHX_0002 BARREL PIN ASSEMBLY - FOR ROUND SCAFFOLDING	ATCNSB_0014 BARREL CALORIMETER SERVICES - IN SECTOR 5 ON SIDE C	Vector coordinate $\Delta X \approx -1.06\text{mm}$ $\Delta Y \approx -0.05\text{mm}$ $\Delta Z \approx 0\text{mm}$	1.07mm	Not inspected
---	---	--	--------	---------------

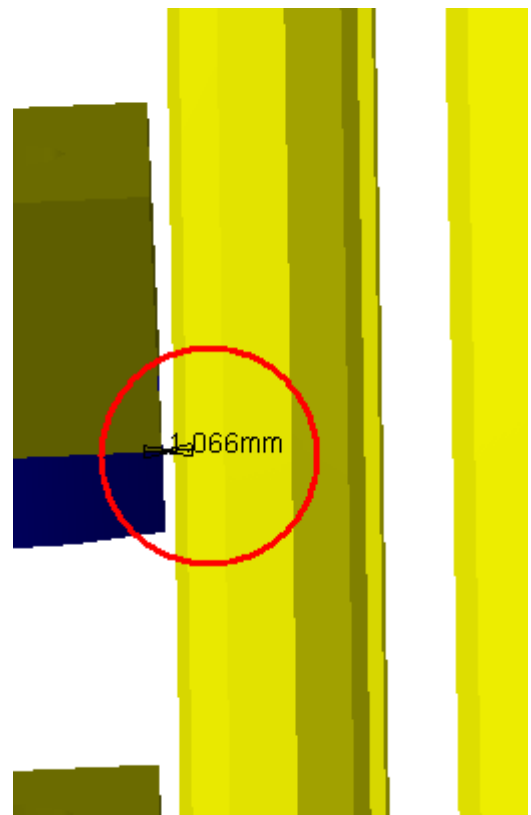
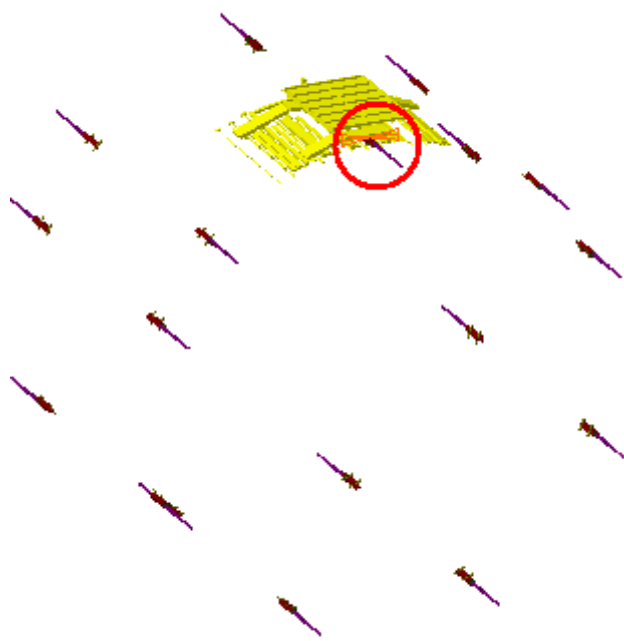

Side C
Sector 5