

# Clearance Publish

Clearance=50mm



Clearance Computation Specification			
Products Selected			
AT802235MQ A.S. Trays on Sect.9	ATCNFX_0010 N2 EXT TL'S & VBN6 - STANDARD DRAWING	41.2	Not Relevant
	ATCNFX_0011 AR EXT TLA1 SH1-USA15-UX15 - STANDARD DRAWING	41.2	Not Relevant
	ATCNFO_0005 UX15 CAVERN - SURVEY - SURVEY BRACKETS ON WALL USA15	30	Not Relevant
	ATCNSB_0010 LAR TOP FT VACUUM LINES ON HS - SIMPLIFIED 3D OBJECT	13.7	Relevant
	ATCNSE_0002 FLEXIBLE CHAINS IN SECTOR 9 FOR - LAR END-CAP CALORIMETER	46.52	Not Relevant

Revised with Peter/Archil 16/11/2005

AT802235MQ A.S. Trays on Sect.9	ATCNFX_0010 N2 EXT TL'S & VBN6 - STANDARD DRAWING	Vector coordinate $\Delta X \approx -41.2\text{mm}$ $\Delta Y \approx 0\text{mm}$ $\Delta Z \approx 0\text{mm}$	41.2mm	Not Relevant
---------------------------------	---	--	--------	--------------

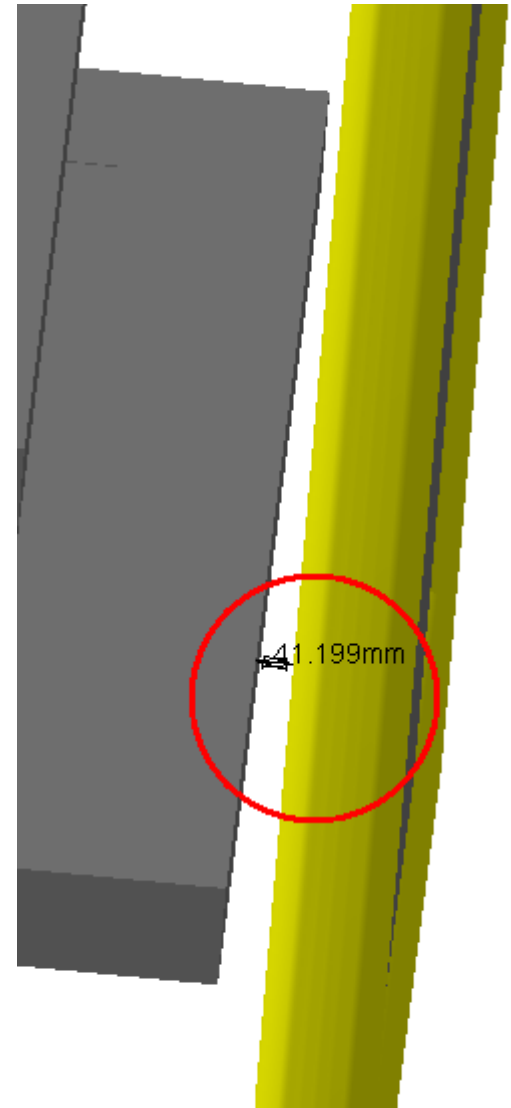
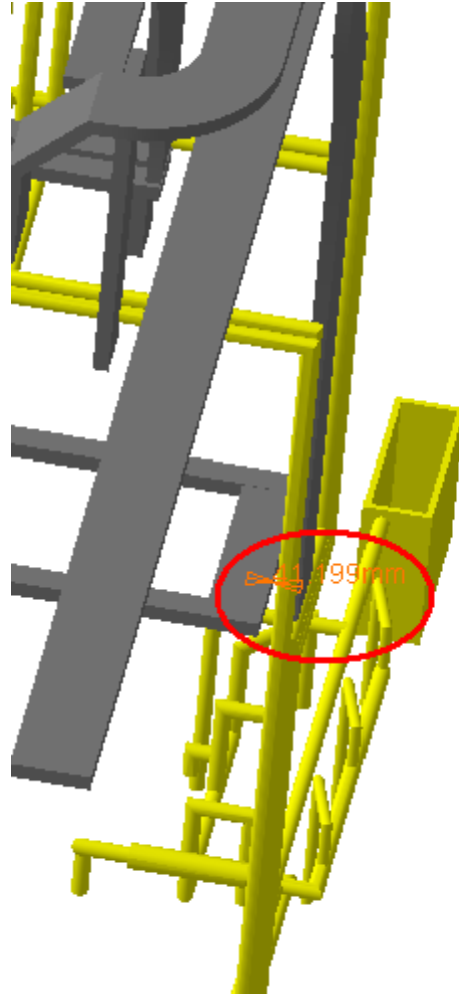
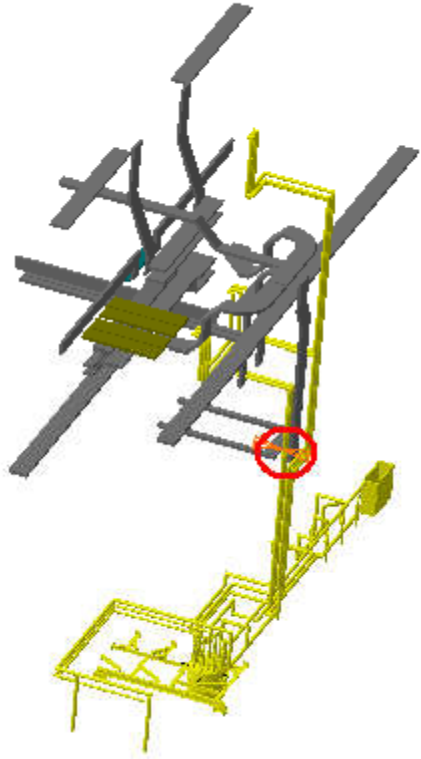

Side C  
Sector 9

AT802235MQ A.S. Trays on Sect.9	ATCNFX_0011 AR EXT TLA1 SH1- USA15-UX15 - STANDARD DRAWING	Vector coordinate $\Delta X \approx -41.2\text{mm}$ $\Delta Y \approx 0\text{mm}$ $\Delta Z \approx 0\text{mm}$	41.2mm	Not Relevant
---------------------------------	--	--	--------	--------------

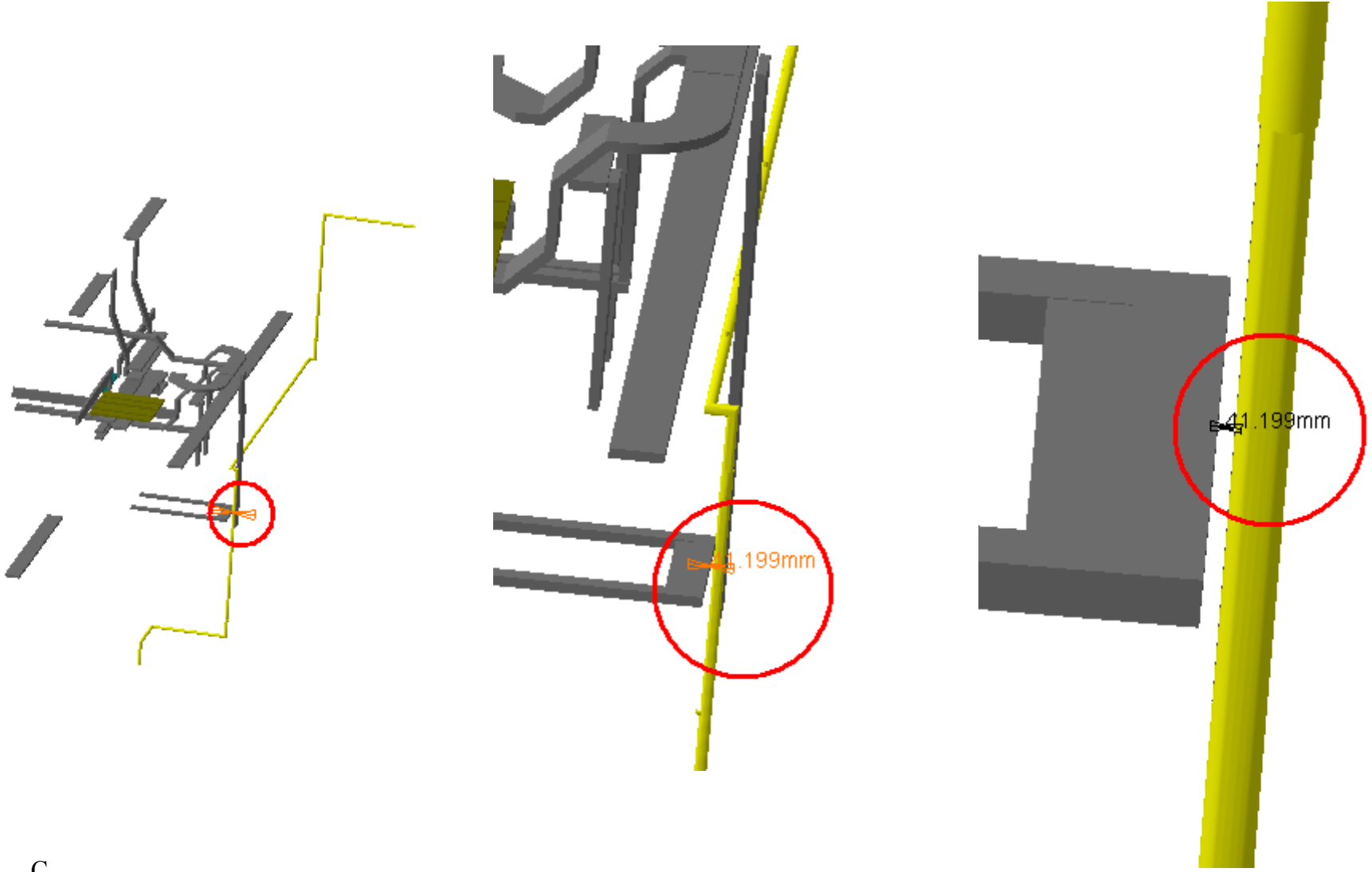

Side C  
Sector 9

AT802235MQ A.S. Trays on Sect.9	ATCNFO_0005 UX15 CAVERN - SURVEY - SURVEY BRACKETS ON WALL USA15	Vector coordinate $\Delta X \approx 0\text{mm}$ $\Delta Y \approx -6.10\text{mm}$ $\Delta Z \approx 30\text{mm}$	30mm	Not Relevant
---------------------------------	--	---	------	--------------

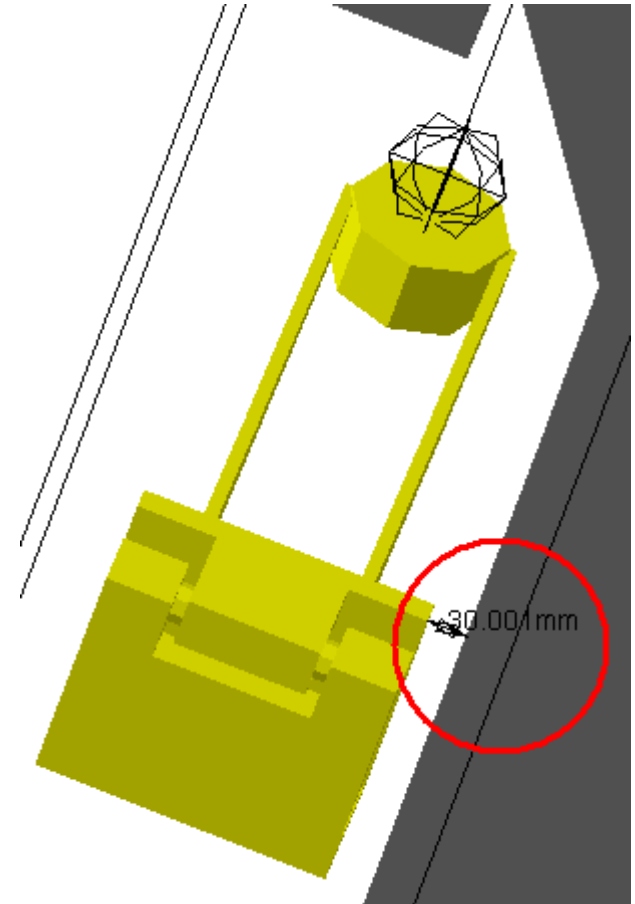
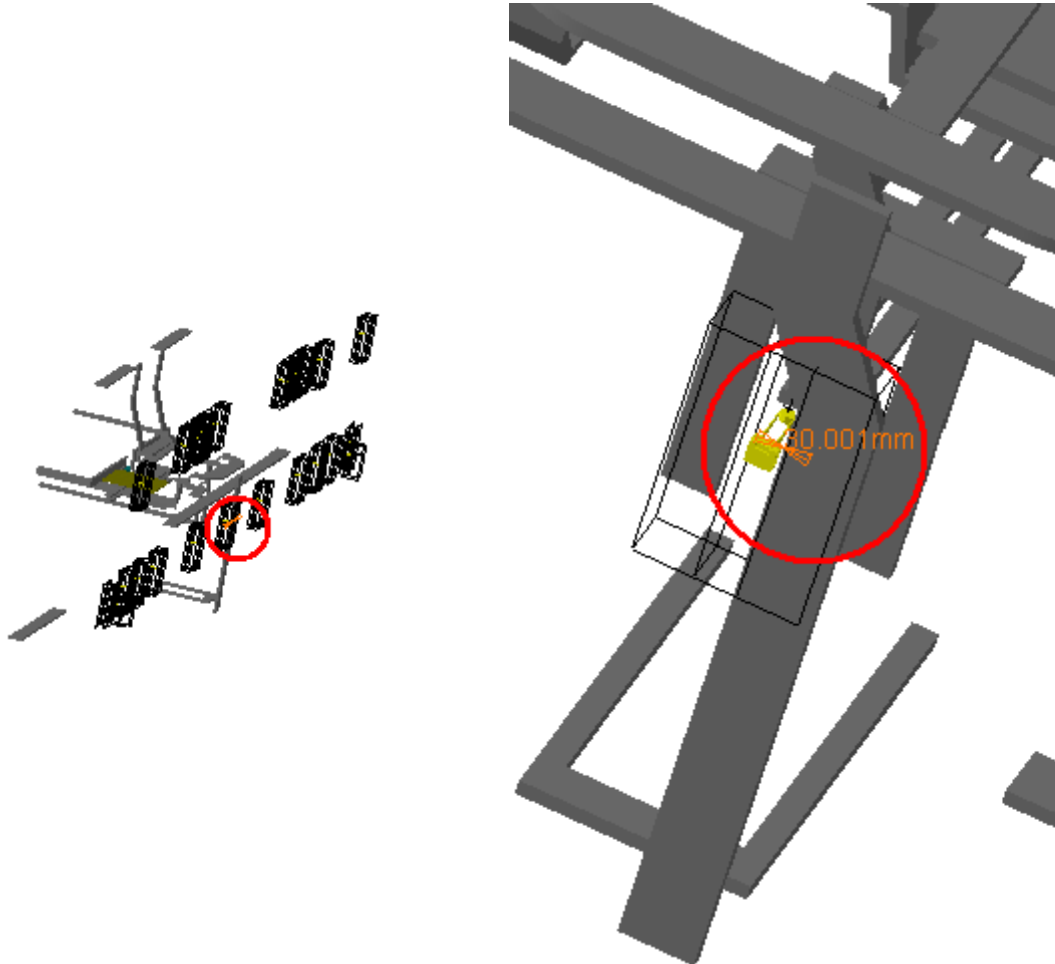

Side A  
Sector 9

RELEVANT

AT802235MQ A.S. Trays on Sect.9	ATCNSB_0010 LAR TOP FT VACUUM LINES ON HS - SIMPLIFIED 3D OBJECT	Vector coordinate $\Delta X \approx -13.7\text{mm}$ $\Delta Y \approx 0\text{mm}$ $\Delta Z \approx 0\text{mm}$	13.7mm	Relevant
---------------------------------	--	--	--------	----------

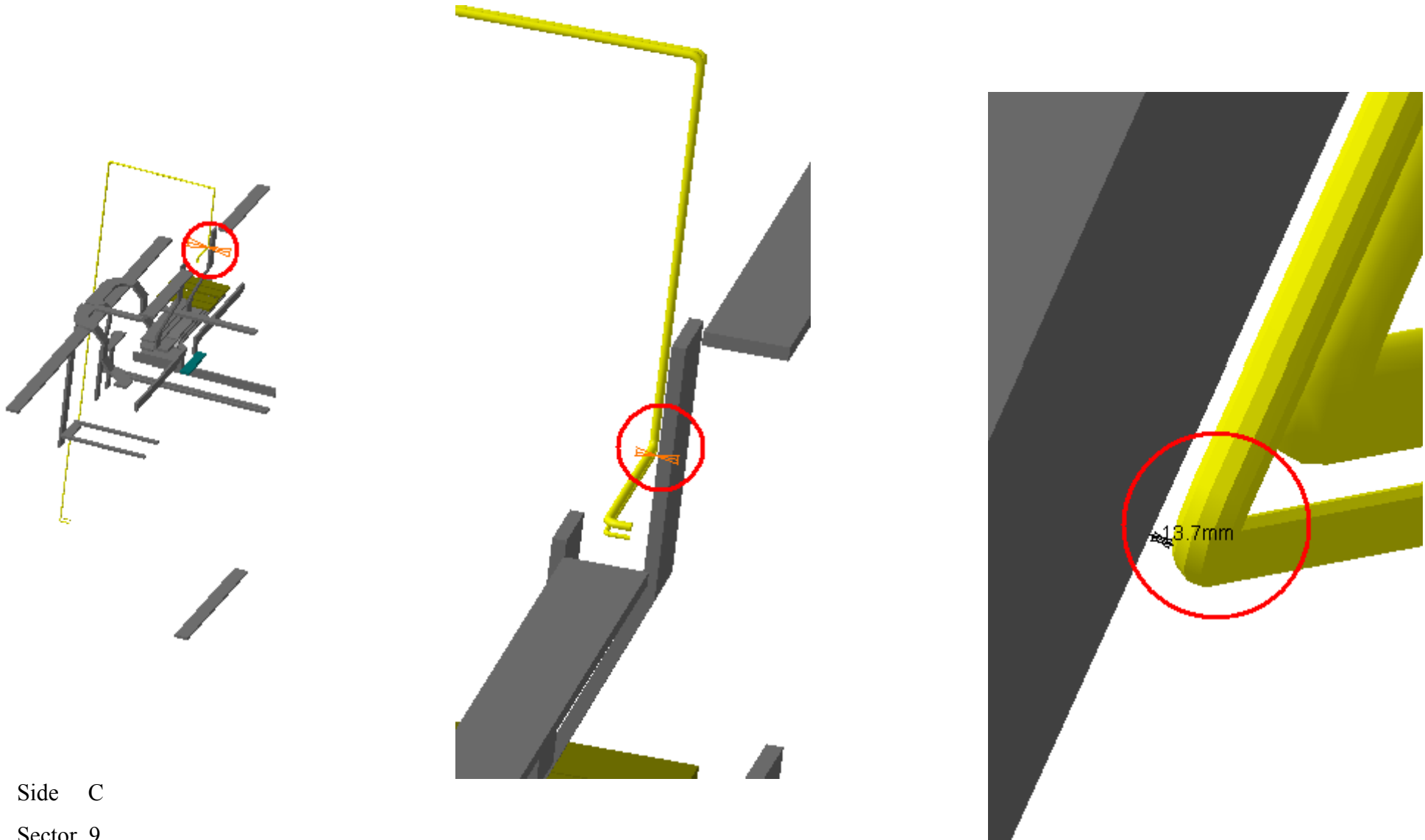

Side C  
Sector 9

AT802235MQ A.S. Trays on Sect.9	ATCNSE_0002 FLEXIBLE CHAINS IN SECTOR 9 FOR - LAR END-CAP CALORIMETER	Vector coordinate $\Delta X \approx 0\text{mm}$ $\Delta Y \approx -46.52\text{mm}$ $\Delta Z \approx 0\text{mm}$	46.52mm	Not Relevant
---------------------------------	---	---	---------	--------------

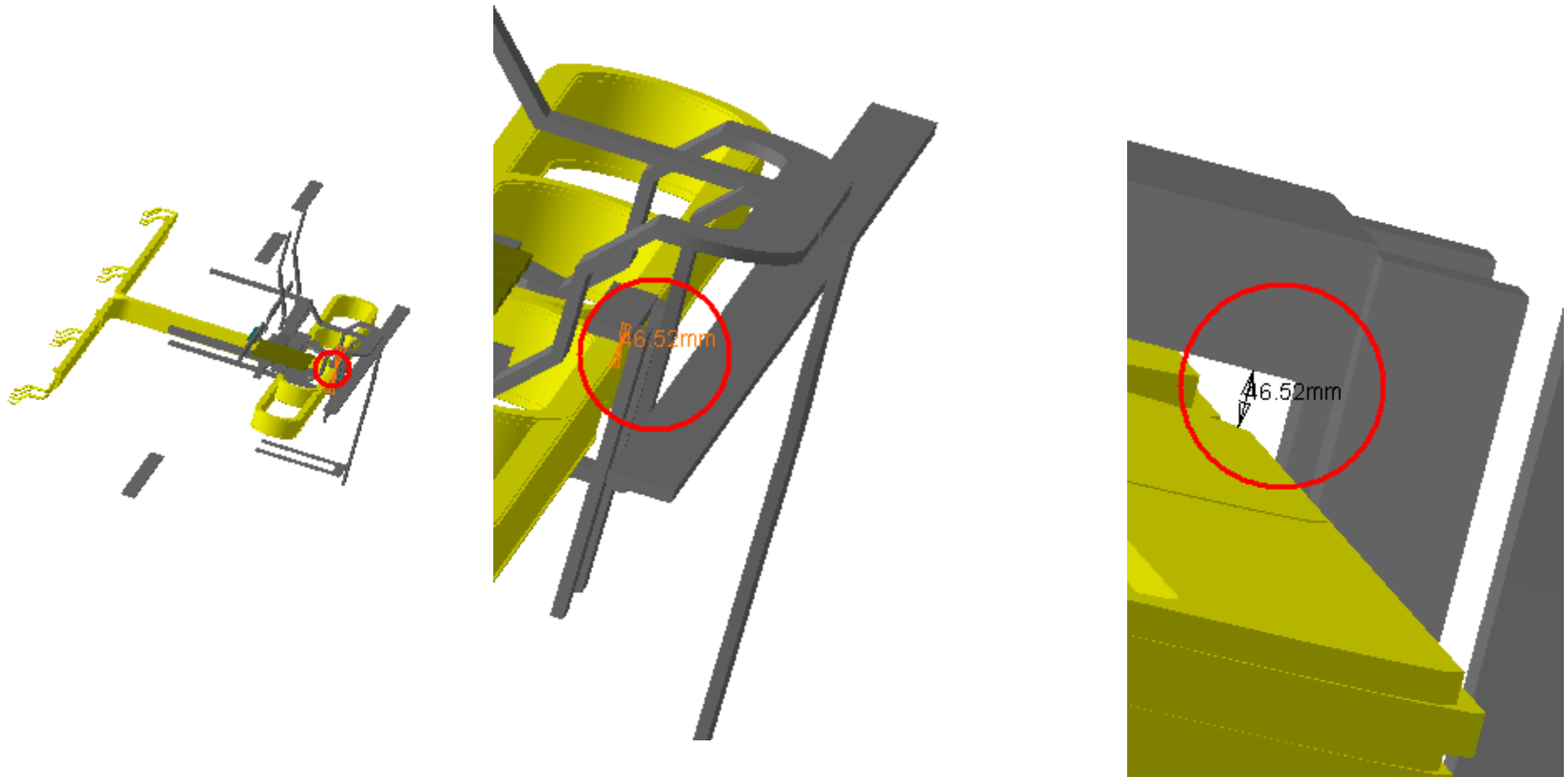

Side C  
Sector 9